

Operating Temperature: 0°C~70°C
 Operating Humidity: 20%~80% (no condensation)
 Storage Temperature: -25°C~85°C
 Storage Humidity: 20%~80% (no condensation)

L:
 CBL-D302MBSS-5m 5000mm±30mm
 CBL-D302MBSS-7m 7000mm±30mm
 CBL-D302MBSS-10m 10000mm±30mm

No	MATERIALS LIST:
1.	CABLE:UL2725 (28AWG*1PR+D+AM)x2C+28AWG*1PR+24AWG*1C+AM+B OD:5.6mm PVC JACKET COLOR:BLACK
2.	CONNECTOR:USB 3.0 A/M, 9P, BLUE INSULATOR SOLDER TYPE, NICKEL PLATED SHELL
3.	CONNECTOR:USB 3.0 MicroB/M, 10P, BLACK INSULATOR SOLDER TYPE, NICKEL PLATED SHELL
4.	PVC MOLDED HOUSING, BLACK COLOR
5.	SCREW:#4x33 M2
6.	SCREW:#4x34.5 M2

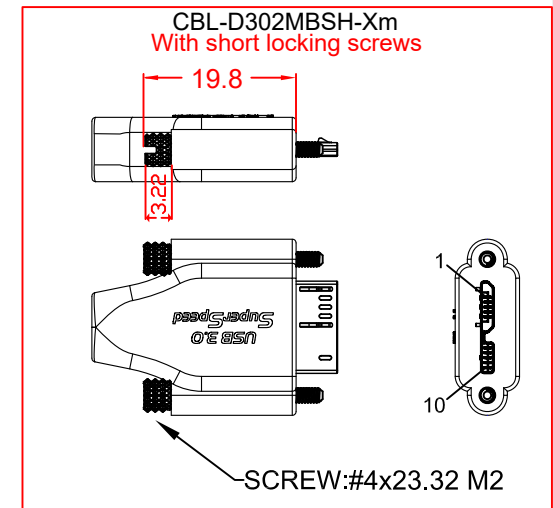
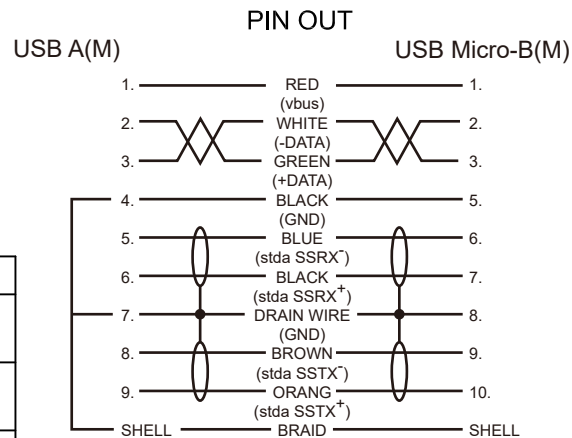

Jargy part no.	Client part no.	Approved	SCALE	UNIT
CBL-D302MBSS-Xm				mm
Drawing Name		Drawn	Date	REV.
USB 3.0 A to MicroB Cable M/M				1.0

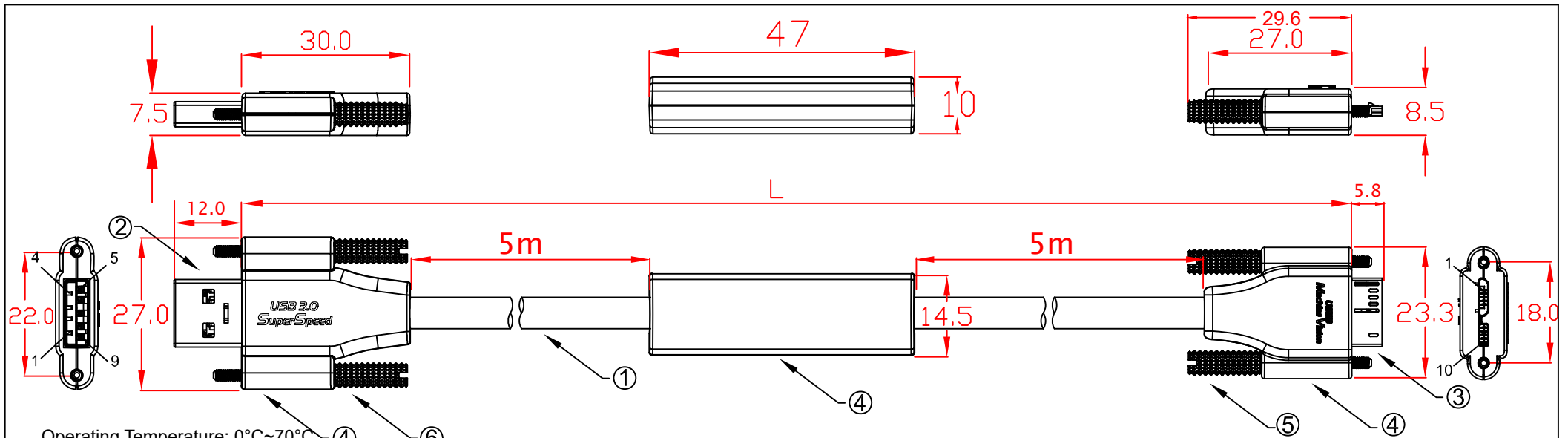

Operating Temperature: 0°C~70°C ④
 Operating Humidity: 20%~80% (no condensation)
 Storage Temperature: -25°C~85°C
 Storage Humidity: 20%~80% (no condensation)

L:
 CBL-D302MBSS-5m 5000mm±30mm
 CBL-D302MBSS-7m 7000mm±30mm
 CBL-D302MBSS-10m 10000mm±30mm

No	MATERIALS LIST:
1.	CABLE:UL2725 (28AWG*1PR+D+AM)x2C+28AWG*1PR+24AWG*1C+AM+B OD:5.6mm PVC JACKET COLOR:BLACK
2.	CONNECTOR:USB 3.0 A/M, 9P, BLUE INSULATOR SOLDER TYPE, NICKEL PLATED SHELL
3.	CONNECTOR:USB 3.0 MicroB/M, 10P, BLACK INSULATOR SOLDER TYPE, NICKEL PLATED SHELL
4.	ABS HOUSING, BLACK COLOR
5.	SCREW:#4x33 M2
6.	SCREW:#4x34.5 M2

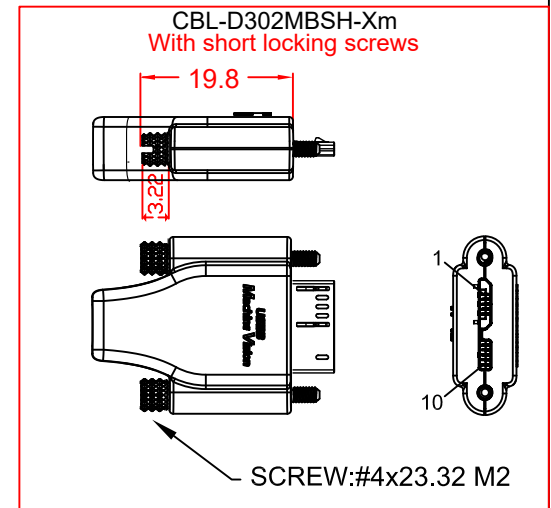
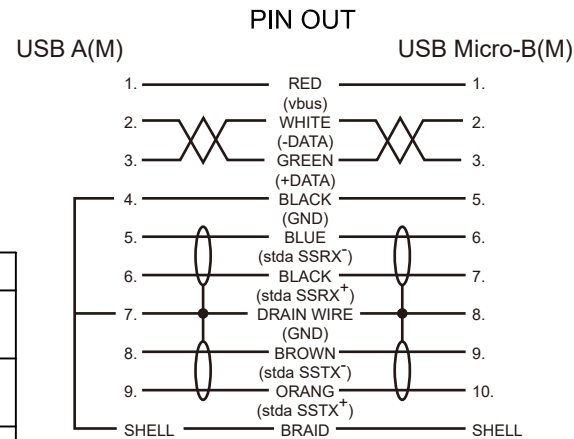

Jargy part no.	Client part no.	Approved	SCALE	UNIT
CBL-D302MBSS-Xm				mm
Drawing Name		Drawn	Date	REV.
USB 3.0 A to MicroB Cable M/M				1.0

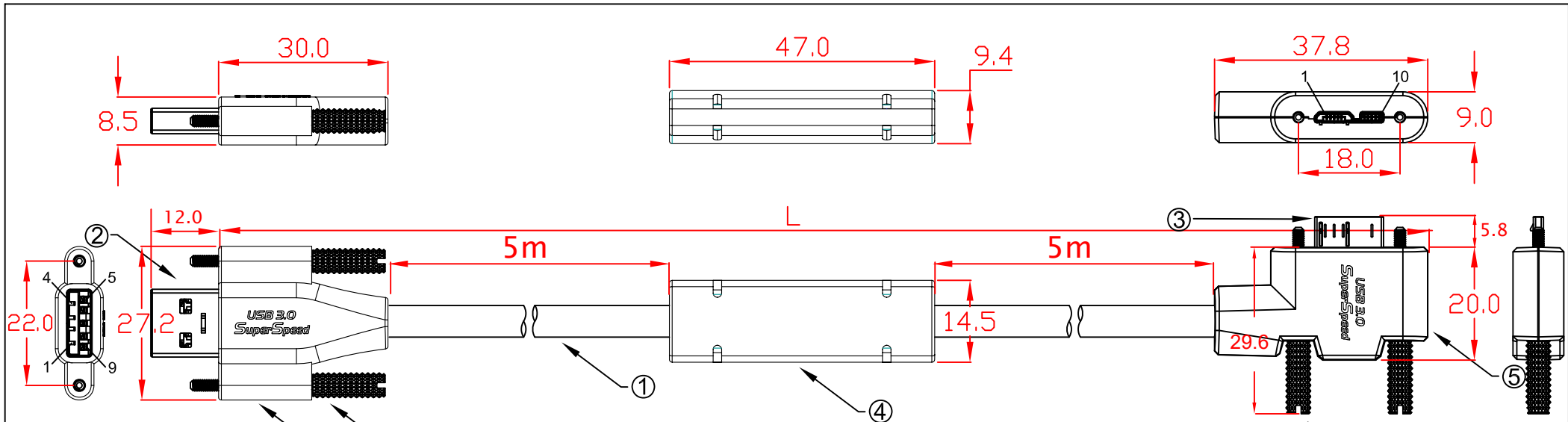

Operating Temperature: 0°C~70°C
 Operating Humidity: 20%~80% (no condensation)
 Storage Temperature: -25°C~85°C
 Storage Humidity: 20%~80% (no condensation)

L:
 CBL-D302MBSS-5mLA 5000mm±30mm
 CBL-D302MBSS-7mLA 7000mm±30mm
 CBL-D302MBSS-10mLA 10000mm±30mm

No	MATERIALS LIST:
1.	CABLE:UL2725 (28AWG*1PR+D+AM)x2C+28AWG*1PR+24AWG*1C+AM+B OD:5.6mm PVC JACKET COLOR:BLACK
2.	CONNECTOR:USB 3.0 A/M, 9P, BLUE INSULATOR SOLDER TYPE, NICKEL PLATED SHELL
3.	CONNECTOR:USB 3.0 MicroB/M, 10P, BLACK INSULATOR SOLDER TYPE, NICKEL PLATED SHELL
4.	PVC MOLDED HOUSING, BLACK COLOR
5.	ABS ASSEMBLY HOUSING, BLACK COLOR
6.	SCREW:#4x33 M2

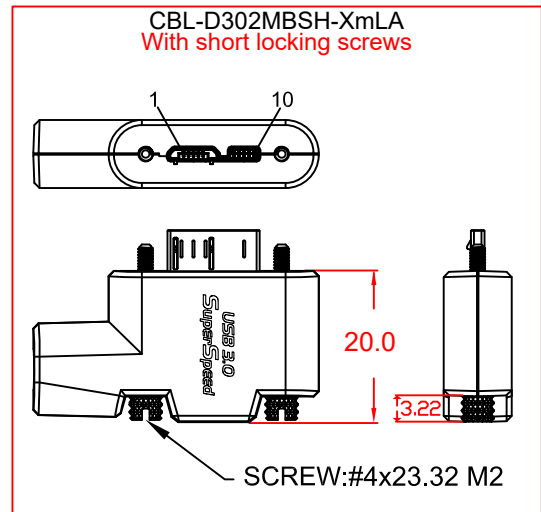
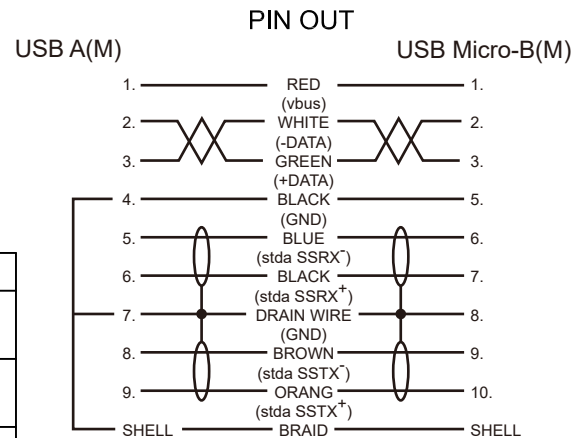

Jargy part no.	Client part no.	Approved	SCALE	UNIT
CBL-D302MBSS-XmLA				mm
Drawing Name		Drawn	Date	REV.
USB 3.0 A to MicroB Cable M/M				1.0

Mobile Computing JARGY

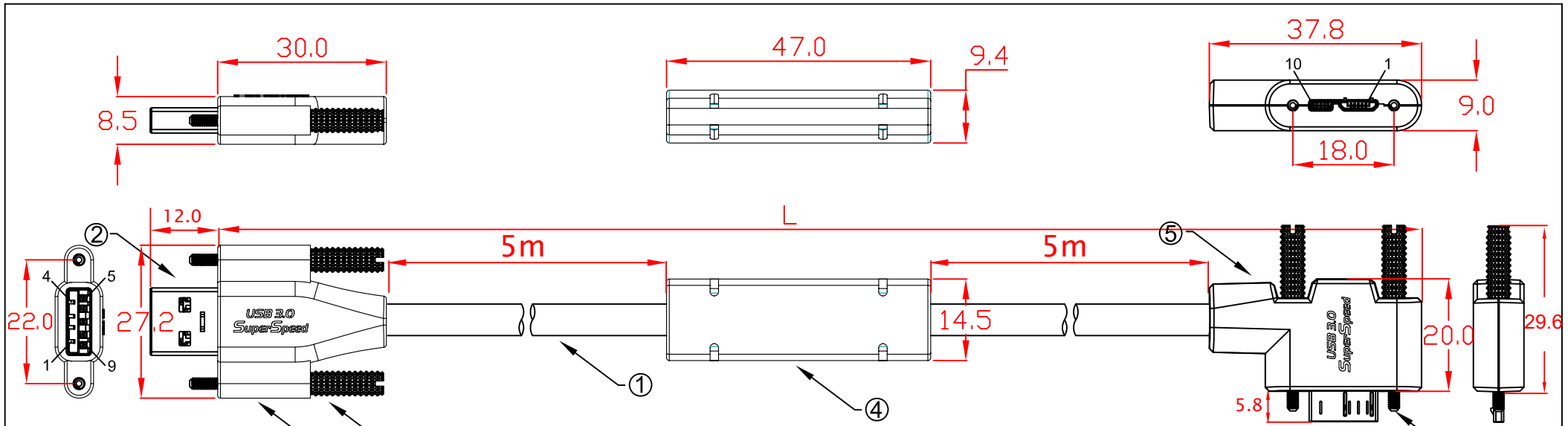

Operating Temperature: 0°C~70°C (4) (7)
 Operating Humidity: 20%~80% (no condensation)
 Storage Temperature: -25°C~85°C
 Storage Humidity: 20%~80% (no condensation)

L:
 CBL-D302MBSS-5mRA 5000mm±30mm
 CBL-D302MBSS-7mRA 7000mm±30mm
 CBL-D302MBSS-10mRA 10000mm±30mm

No	MATERIALS LIST:
1.	CABLE:UL2725 (28AWG*1PR+D+AM)x2C+28AWG*1PR+24AWG*1C+AM+B OD:5.6mm PVC JACKET COLOR:BLACK
2.	CONNECTOR:USB 3.0 A/M, 9P, BLUE INSULATOR SOLDER TYPE, NICKEL PLATED SHELL
3.	CONNECTOR:USB 3.0 MicroB/M, 10P, BLACK INSULATOR SOLDER TYPE, NICKEL PLATED SHELL
4.	PVC MOLDED HOUSING, BLACK COLOR
5.	ABS ASSEMBLY HOUSING, BLACK COLOR
6.	SCREW:#4x33 M2
7.	SCREW:#4x34.5 M2

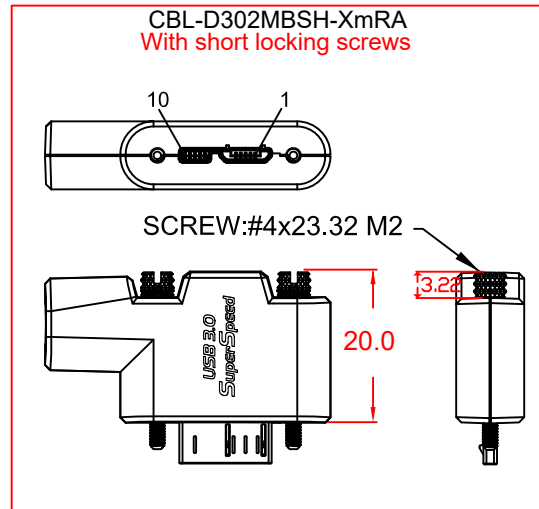
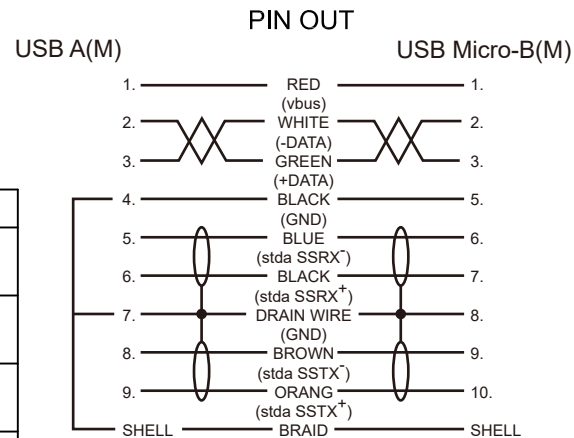

Jargy part no.	Client part no.	Approved	SCALE	UNIT
CBL-D302MBSS-XmRA				mm
Drawing Name		Drawn	Date	REV.
USB 3.0 A to MicroB Cable M/M				1.0

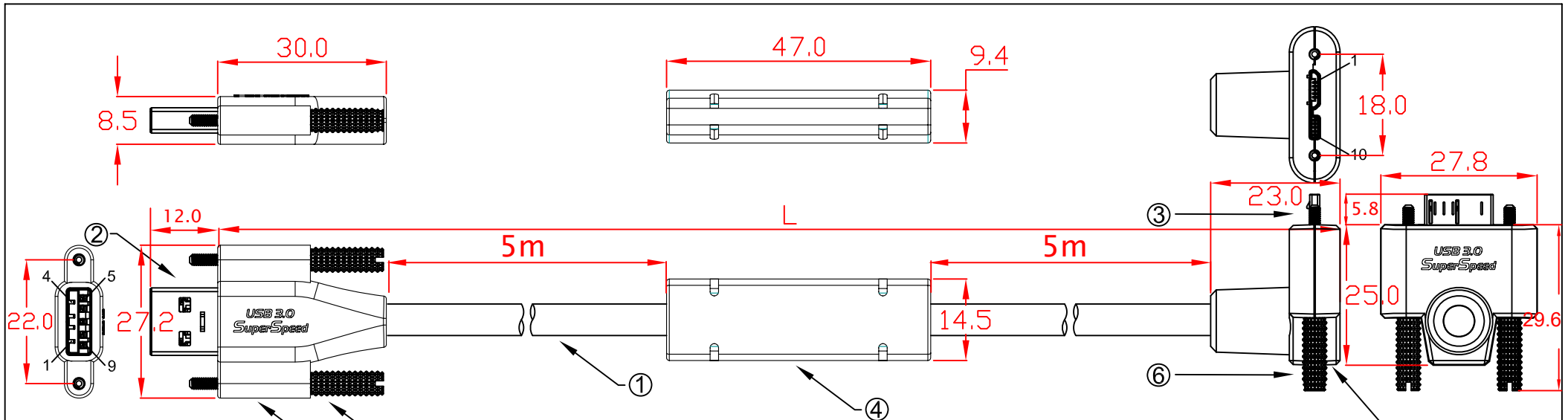

Operating Temperature: 0°C~70°C (4) (7)
 Operating Humidity: 20%~80% (no condensation)
 Storage Temperature: -25°C~85°C
 Storage Humidity: 20%~80% (no condensation)

L:
 CBL-D302MBSS-5mUA 5000mm±30mm
 CBL-D302MBSS-7mUA 7000mm±30mm
 CBL-D302MBSS-10mUA 10000mm±30mm

No	MATERIALS LIST:
1.	CABLE:UL2725 (28AWG*1PR+D+AM)x2C+28AWG*1PR+24AWG*1C+AM+B OD:5.6mm PVC JACKET COLOR:BLACK
2.	CONNECTOR:USB 3.0 A/M, 9P, BLUE INSULATOR SOLDER TYPE, NICKEL PLATED SHELL
3.	CONNECTOR:USB 3.0 MicroB/M, 10P, BLACK INSULATOR SOLDER TYPE, NICKEL PLATED SHELL
4.	PVC MOLDED HOUSING, BLACK COLOR
5.	ABS ASSEMBLY HOUSING, BLACK COLOR
6.	SCREW:#4x33 M2
7.	SCREW:#4x34.5 M2

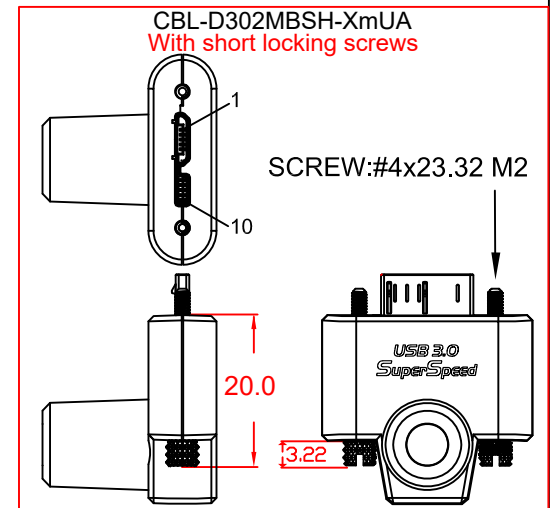
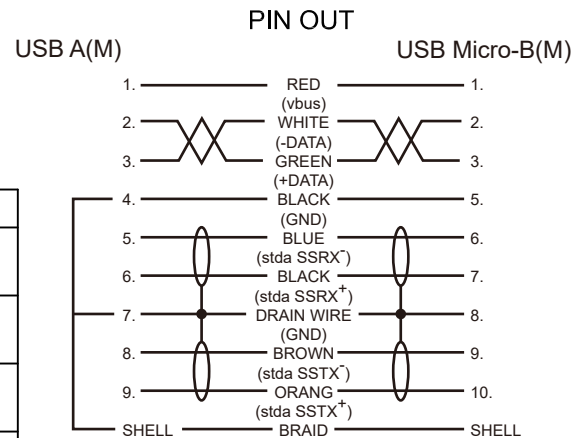

Jargy part no.	Client part no.	Approved	SCALE	UNIT
CBL-D302MBSS-XmUA				mm
Drawing Name		Drawn	Date	REV.
USB 3.0 A to MicroB Cable M/M				1.0

Mobile Computing JARGY

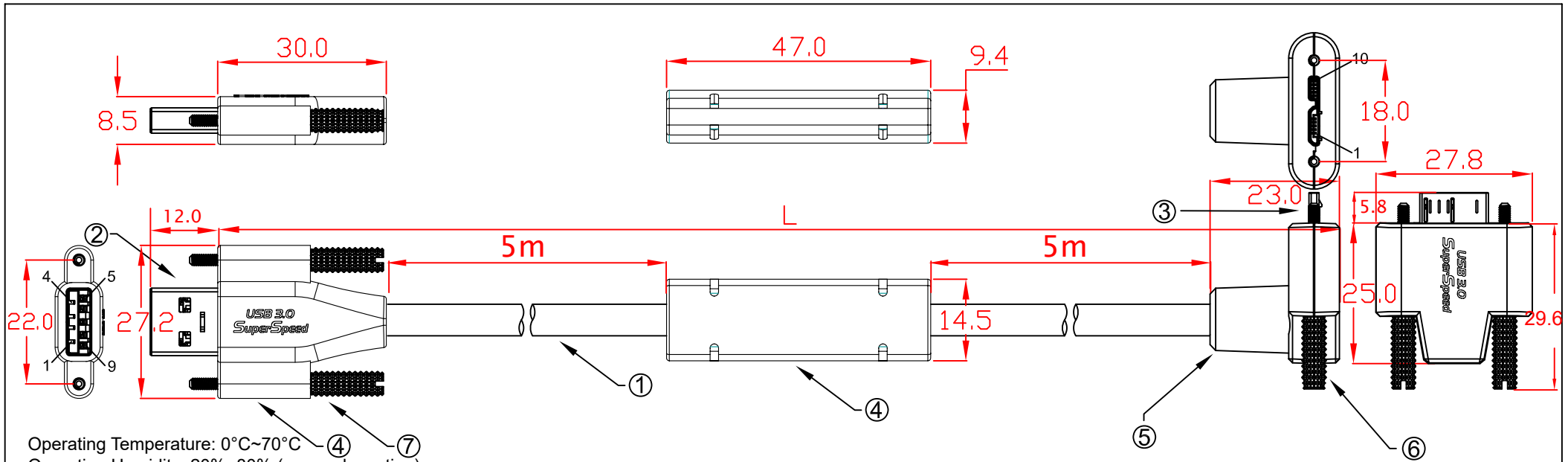

Operating Temperature: 0°C~70°C
 Operating Humidity: 20%~80% (no condensation)
 Storage Temperature: -25°C~85°C
 Storage Humidity: 20%~80% (no condensation)

L:
 CBL-D302MBSS-5mDA 5000mm±30mm
 CBL-D302MBSS-7mDA 7000mm±30mm
 CBL-D302MBSS-10mDA 10000mm±30mm

No	MATERIALS LIST:
1.	CABLE:UL2725 (28AWG*1PR+D+AM)x2C+28AWG*1PR+24AWG*1C+AM+B OD:5.6mm PVC JACKET COLOR:BLACK
2.	CONNECTOR:USB 3.0 A/M, 9P, BLUE INSULATOR SOLDER TYPE, NICKEL PLATED SHELL
3.	CONNECTOR:USB 3.0 MicroB/M, 10P, BLACK INSULATOR SOLDER TYPE, NICKEL PLATED SHELL
4.	PVC MOLDED HOUSING, BLACK COLOR
5.	ABS ASSEMBLY HOUSING, BLACK COLOR
6.	SCREW:#4x33 M2
7.	SCREW:#4x34.5 M2

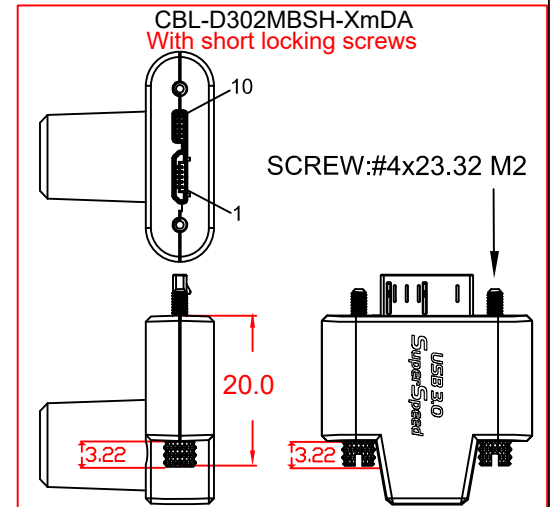
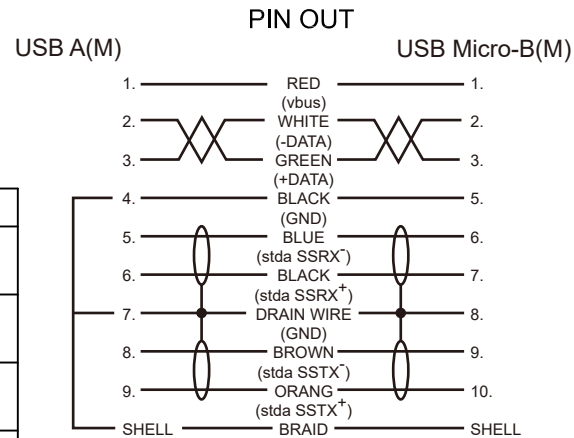

Jargy part no.	Client part no.	Approved	SCALE	UNIT
CBL-D302MBSS-XmDA				mm
Drawing Name		Drawn	Date	REV.
USB 3.0 A to MicroB Cable M/M				1.0

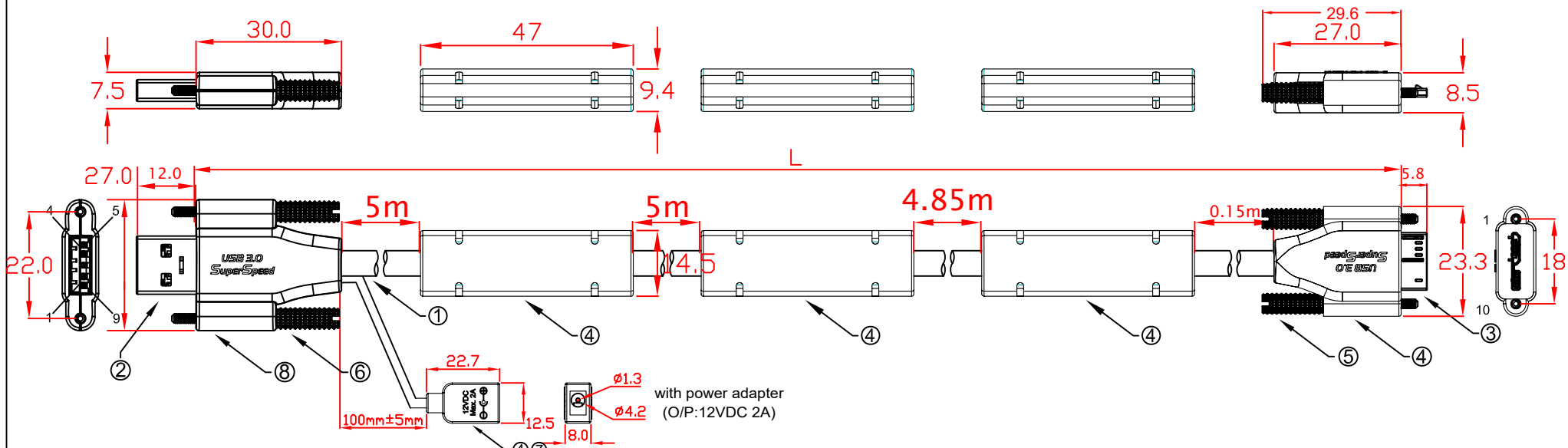

Operating Temperature: 0°C~70°C
 Operating Humidity: 20%~80% (no condensation)
 Storage Temperature: -25°C~85°C
 Storage Humidity: 20%~80% (no condensation)

L:
 CBL-D302MBSSWBPW-15m 15000mm±50mm

No	MATERIALS LIST:
1.	CABLE:UL2725 (28AWG*1PR+D+AM)x2C+28AWG*1PR+24AWG*1C+AM+B OD:5.6mm PVC JACKET COLOR:BLACK
2.	CONNECTOR:USB 3.0 A/M, 9P, BLUE INSULATOR SOLDER TYPE, NICKEL PLATED SHELL
3.	CONNECTOR:USB 3.0 MicroB/M, 10P, BLACK INSULATOR SOLDER TYPE, NICKEL PLATED SHELL
4.	PVC MOLDED HOUSING, BLACK COLOR
5.	SCREW:#4x33 M2
6.	SCREW:#4x34.5 M2
7.	DC JACK 1.3mm 30V 0.3V
8.	ABS HOUSING, BLACK COLOR

PIN OUT

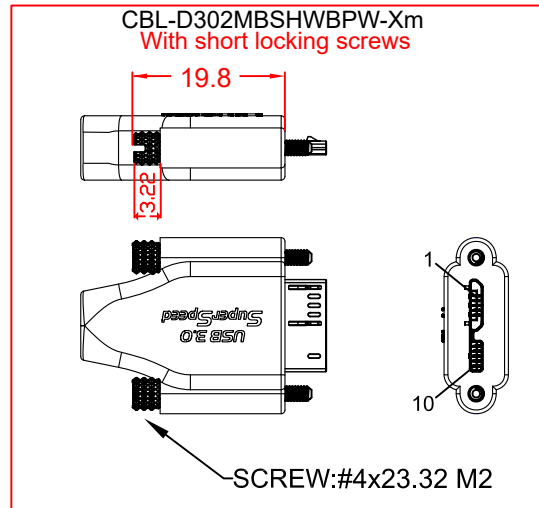
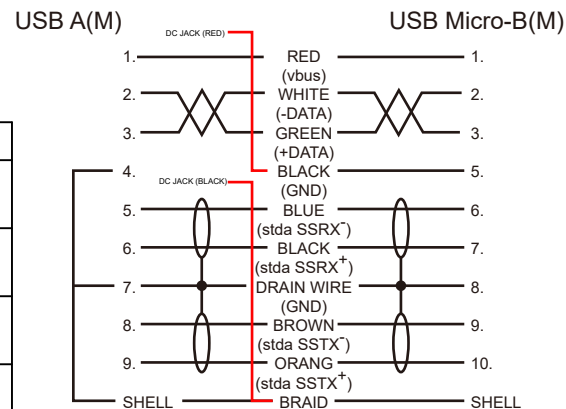

Jargy part no.	Client part no.	Approved	SCALE	UNIT
CBL-D302MBSSWBPW-15m				mm
Drawing Name		Drawn	Date	REV.
USB 3.0 A to MicroB Cable M/M				1.0

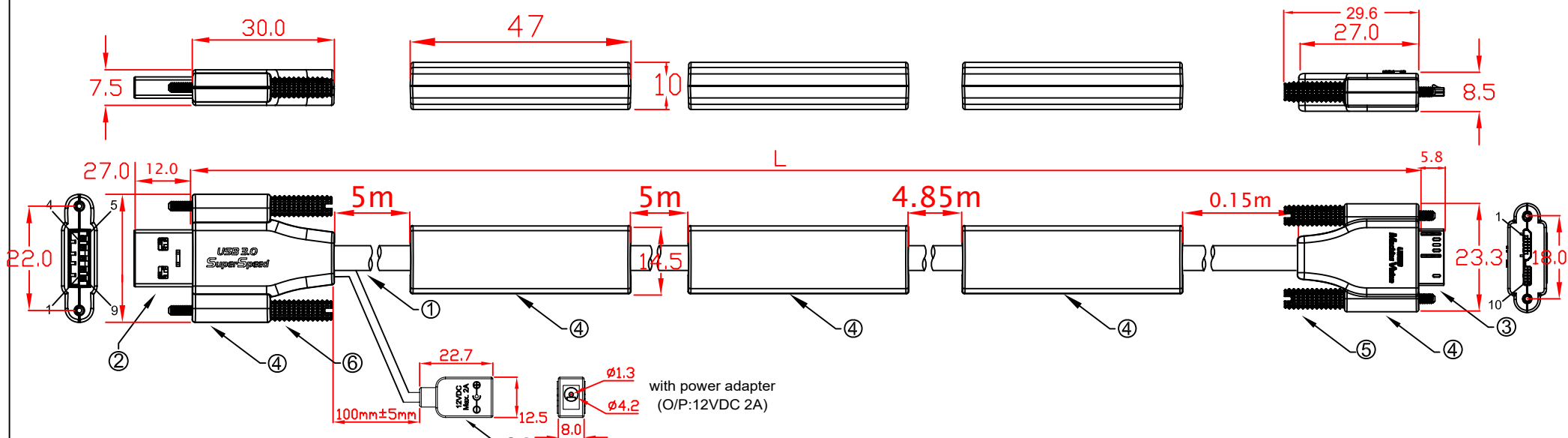

Operating Temperature: 0°C~70°C
 Operating Humidity: 20%~80% (no condensation)
 Storage Temperature: -25°C~85°C
 Storage Humidity: 20%~80% (no condensation)

L:
 CBL-D302MBSSWBPW-15m 15000mm±50mm

No	MATERIALS LIST:
1.	CABLE:UL2725 (28AWG*1PR+D+AM)x2C+28AWG*1PR+24AWG*1C+AM+B OD:5.6mm PVC JACKET COLOR:BLACK
2.	CONNECTOR:USB 3.0 A/M, 9P, BLUE INSULATOR SOLDER TYPE, NICKEL PLATED SHELL
3.	CONNECTOR:USB 3.0 MicroB/M, 10P, BLACK INSULATOR SOLDER TYPE, NICKEL PLATED SHELL
4.	ABS HOUSING, BLACK COLOR
5.	SCREW:#4x33 M2
6.	SCREW:#4x34.5 M2
7.	DC JACK 1.3mm 30V 0.3V
8.	PVC MOLDED HOUSING, BLACK COLOR

PIN OUT

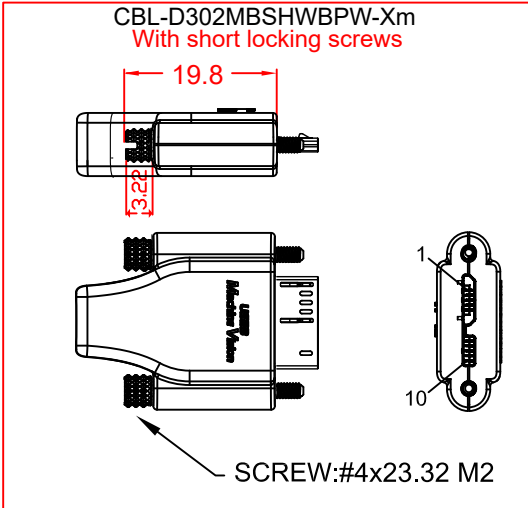
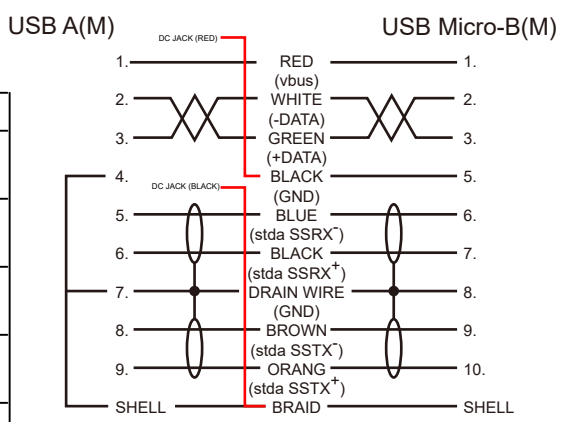

Jargy part no.	Client part no.	Approved	SCALE	UNIT
CBL-D302MBSSWBPW-15m				mm
Drawing Name		Drawn	Date	REV.
USB 3.0 A to MicroB Cable M/M				1.0

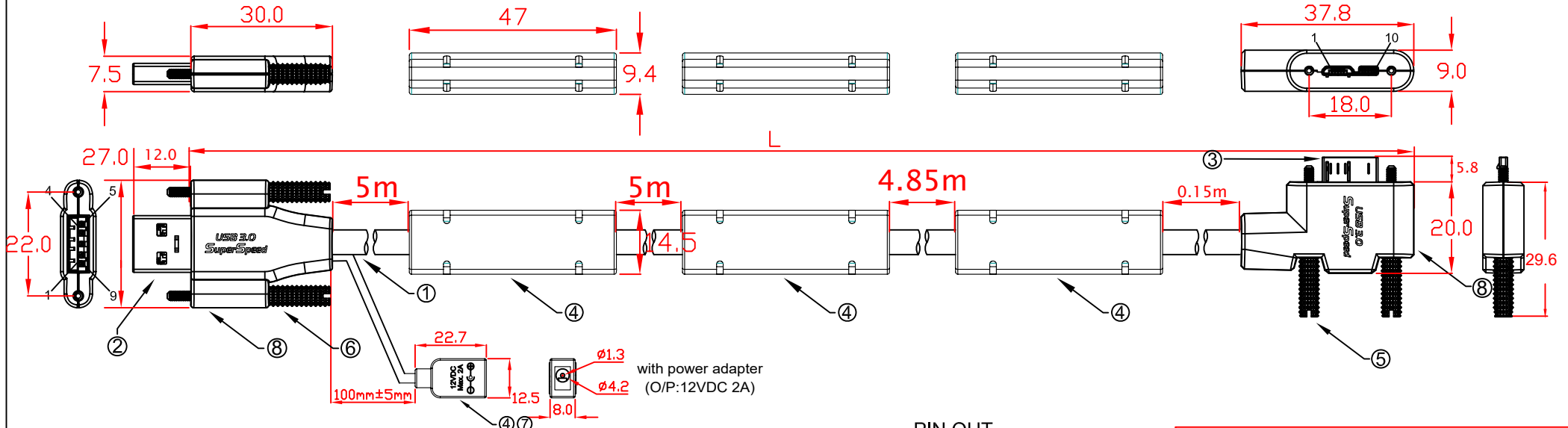

Operating Temperature: 0°C~70°C
 Operating Humidity: 20%~80% (no condensation)
 Storage Temperature: -25°C~85°C
 Storage Humidity: 20%~80% (no condensation)

L:
 CBL-D302MBSSWBPW-15mLA 15000mm±50mm

No	MATERIALS LIST:
1.	CABLE:UL2725 (28AWG*1PR+D+AM)x2C+28AWG*1PR+24AWG*1C+AM+B OD:5.6mm PVC JACKET COLOR:BLACK
2.	CONNECTOR:USB 3.0 A/M, 9P, BLUE INSULATOR SOLDER TYPE, NICKEL PLATED SHELL
3.	CONNECTOR:USB 3.0 MicroB/M, 10P, BLACK INSULATOR SOLDER TYPE, NICKEL PLATED SHELL
4.	PVC MOLDED HOUSING, BLACK COLOR
5.	SCREW:#4x33 M2
6.	SCREW:#4x34.5 M2
7.	DC JACK 1.3mm 30V 0.3V
8.	ABS HOUSING, BLACK COLOR

PIN OUT

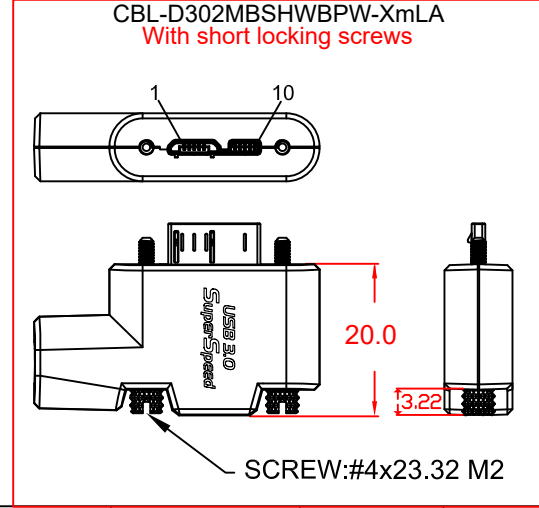
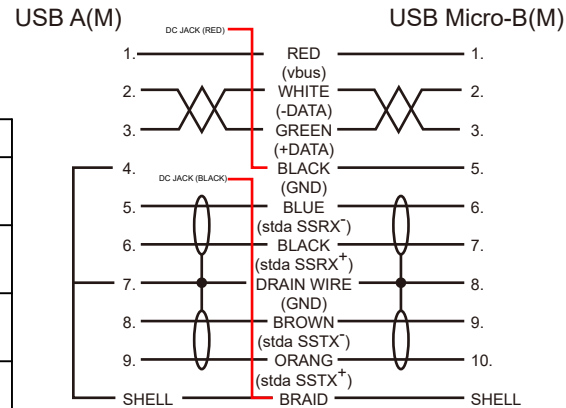

Jargy part no.	Client part no.	Approved	SCALE	UNIT
CBL-D302MBSSWBPW-15mLA				mm
Drawing Name		Drawn	Date	REV.
USB 3.0 A to MicroB Cable M/M				1.0

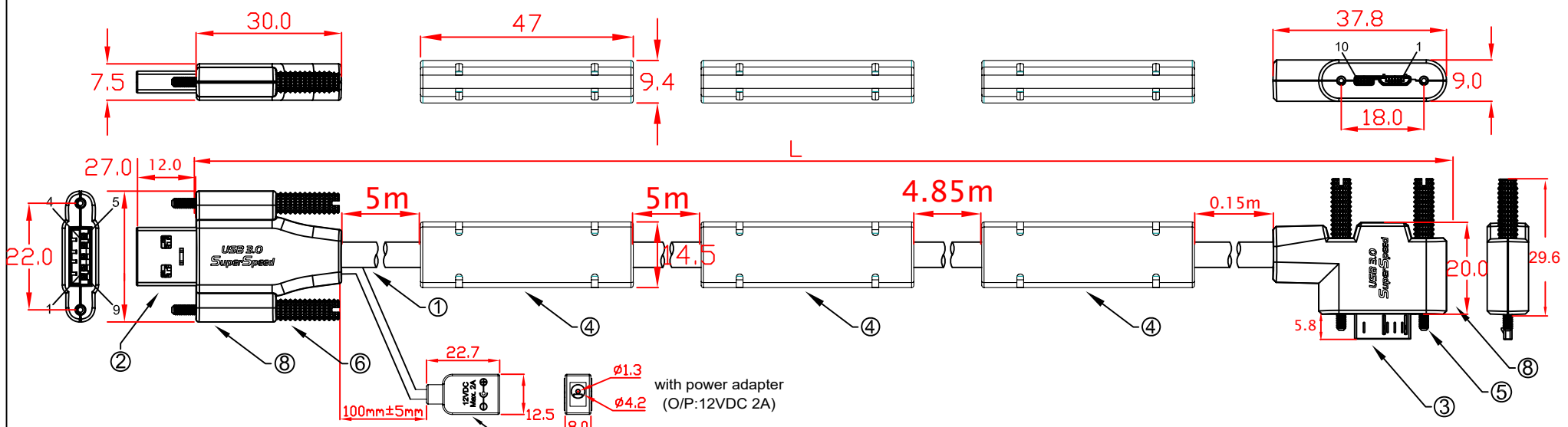

Operating Temperature: 0°C~70°C
 Operating Humidity: 20%~80% (no condensation)
 Storage Temperature: -25°C~85°C
 Storage Humidity: 20%~80% (no condensation)

L:
 CBL-D302MBSSWBPW-15mRA 1500mm±50mm

No	MATERIALS LIST:
1.	CABLE:UL2725 (28AWG*1PR+D+AM)x2C+28AWG*1PR+24AWG*1C+AM+B OD:5.6mm PVC JACKET COLOR:BLACK
2.	CONNECTOR:USB 3.0 A/M, 9P, BLUE INSULATOR SOLDER TYPE, NICKEL PLATED SHELL
3.	CONNECTOR:USB 3.0 MicroB/M, 10P, BLACK INSULATOR SOLDER TYPE, NICKEL PLATED SHELL
4.	PVC MOLDED HOUSING, BLACK COLOR
5.	SCREW:#4x33 M2
6.	SCREW:#4x34.5 M2
7.	DC JACK 1.3mm 30V 0.3V
8.	ABS HOUSING, BLACK COLOR

PIN OUT

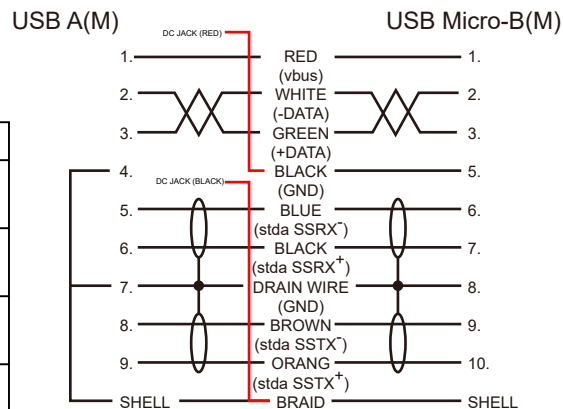

CBL-D302MBSHWBPW-XmRA
 With short locking screws

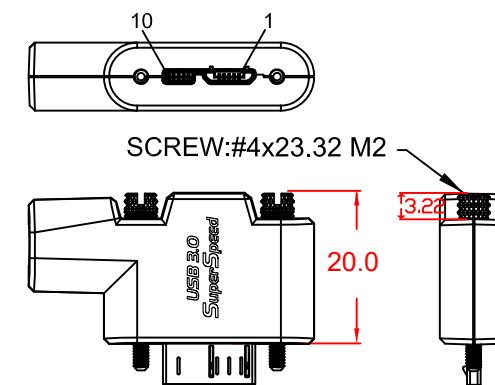

Jargy part no.	Client part no.	Approved	SCALE	UNIT
CBL-D302MBSSWBPW-15mRA				mm
Drawing Name		Drawn	Date	REV.
USB 3.0 A to MicroB Cable M/M				1.0

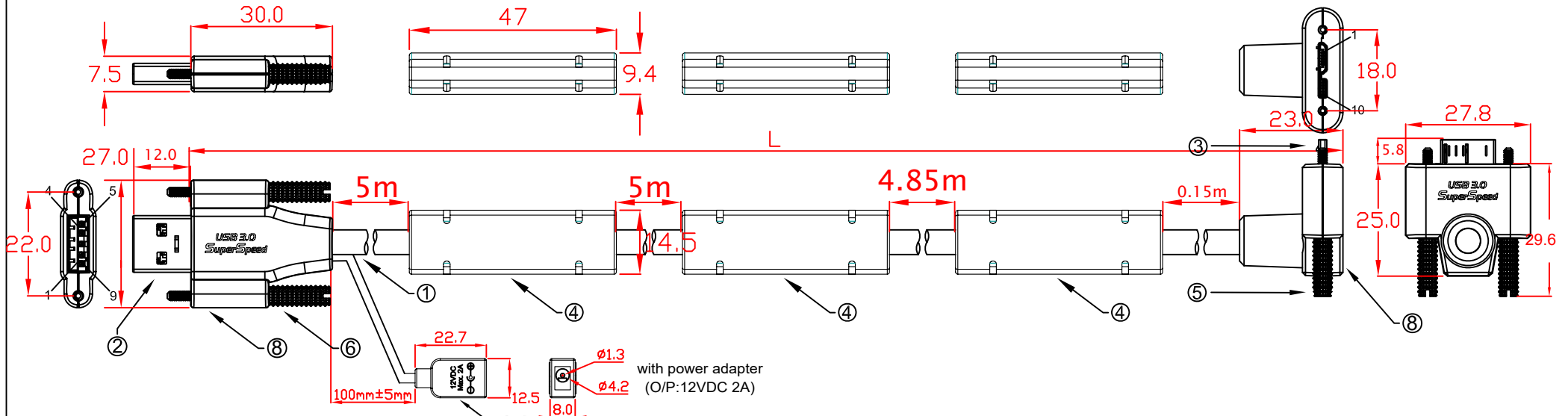

Operating Temperature: 0°C~70°C
 Operating Humidity: 20%~80% (no condensation)
 Storage Temperature: -25°C~85°C
 Storage Humidity: 20%~80% (no condensation)

L:
 CBL-D302MBSSWPW-15mUA 15000mm±50mm

No	MATERIALS LIST:
1.	CABLE:UL2725 (28AWG*1PR+D+AM)x2C+28AWG*1PR+24AWG*1C+AM+B OD:5.6mm PVC JACKET COLOR:BLACK
2.	CONNECTOR:USB 3.0 A/M, 9P, BLUE INSULATOR SOLDER TYPE, NICKEL PLATED SHELL
3.	CONNECTOR:USB 3.0 MicroB/M, 10P, BLACK INSULATOR SOLDER TYPE, NICKEL PLATED SHELL
4.	PVC MOLDED HOUSING, BLACK COLOR
5.	SCREW:#4x33 M2
6.	SCREW:#4x34.5 M2
7.	DC JACK 1.3mm 30V 0.3V
8.	ABS HOUSING, BLACK COLOR

PIN OUT

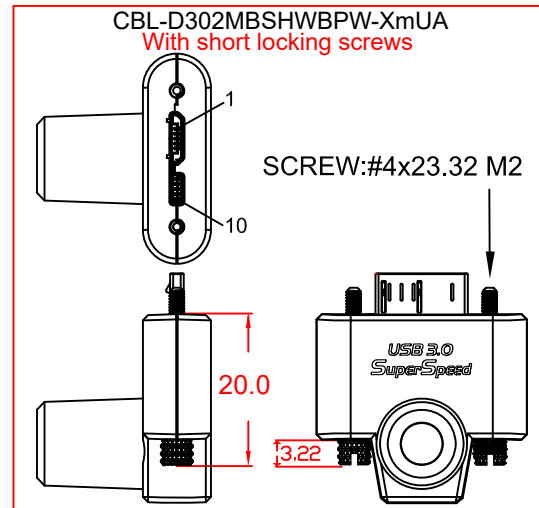
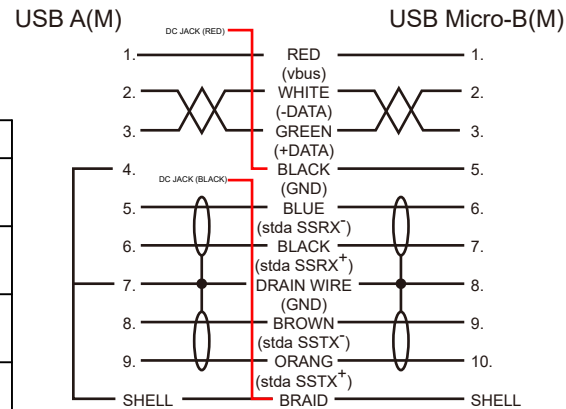

Jargy part no.	Client part no.	Approved	SCALE	UNIT
CBL-D302MBSSWPW-15mUA				mm
Drawing Name		Drawn	Date	REV.
USB 3.0 A to MicroB Cable M/M				1.0

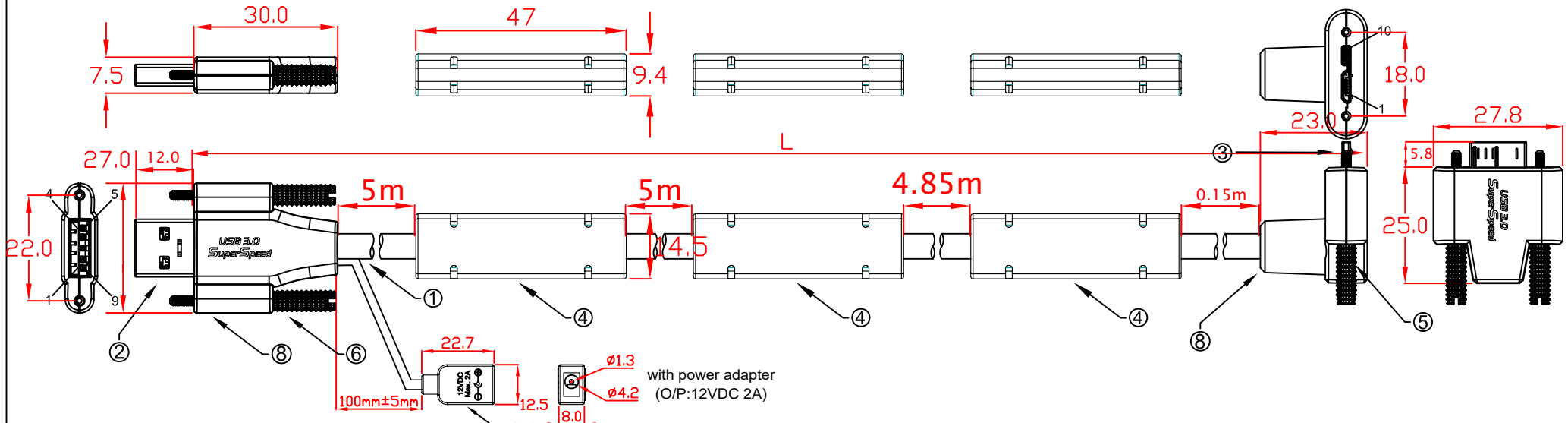

Operating Temperature: 0°C~70°C
 Operating Humidity: 20%~80% (no condensation)
 Storage Temperature: -25°C~85°C
 Storage Humidity: 20%~80% (no condensation)

L:
 CBL-D302MBSSWBPW-15mDA 1500mm±50mm

No	MATERIALS LIST:
1.	CABLE:UL2725 (28AWG*1PR+D+AM)x2C+28AWG*1PR+24AWG*1C+AM+B OD:5.6mm PVC JACKET COLOR:BLACK
2.	CONNECTOR:USB 3.0 A/M, 9P, BLUE INSULATOR SOLDER TYPE, NICKEL PLATED SHELL
3.	CONNECTOR:USB 3.0 MicroB/M, 10P, BLACK INSULATOR SOLDER TYPE, NICKEL PLATED SHELL
4.	PVC MOLDED HOUSING, BLACK COLOR
5.	SCREW:#4x33 M2
6.	SCREW:#4x34.5 M2
7.	DC JACK 1.3mm 30V 0.3V
8.	ABS HOUSING, BLACK COLOR

PIN OUT

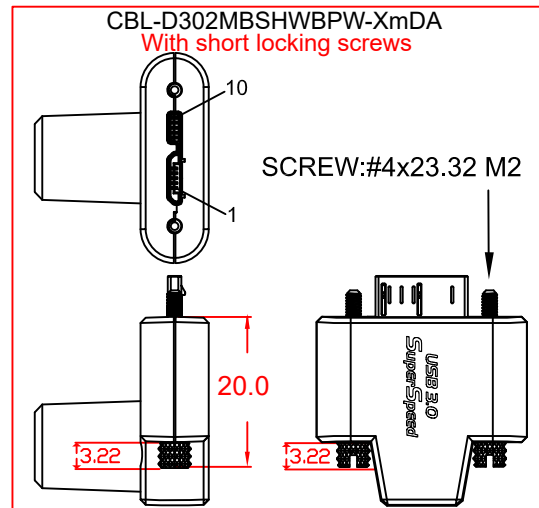
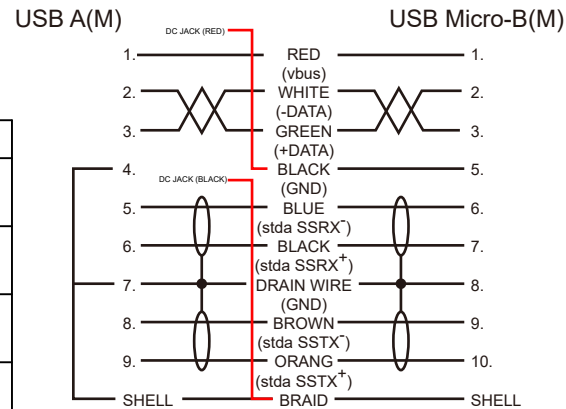

Jargy part no.	Client part no.	Approved	SCALE	UNIT
CBL-D302MBSSWBPW-15mDA				mm
Drawing Name		Drawn	Date	REV.
USB 3.0 A to MicroB Cable M/M				1.0

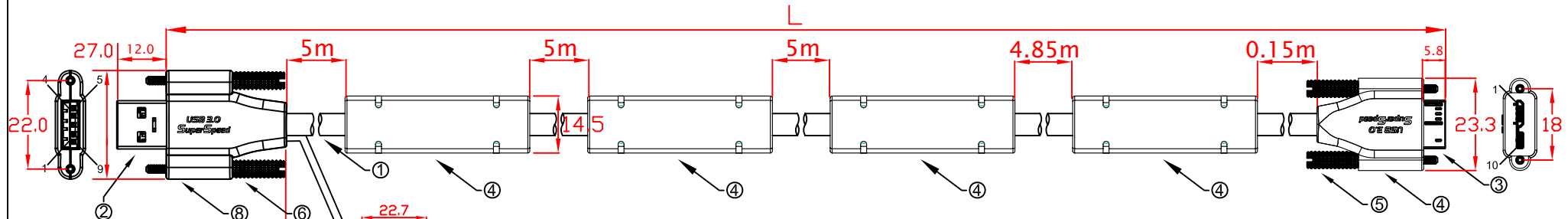
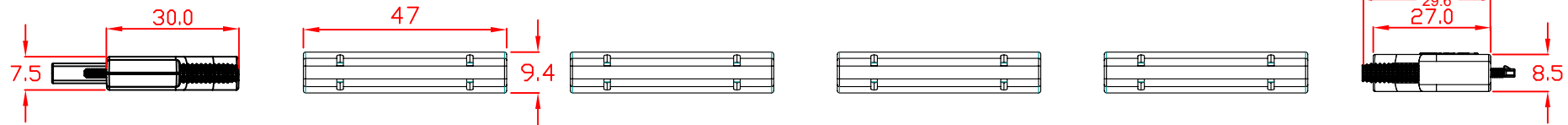

Operating Temperature: 0°C~70°C
 Operating Humidity: 20%~80% (no condensation)
 Storage Temperature: -25°C~85°C
 Storage Humidity: 20%~80% (no condensation)

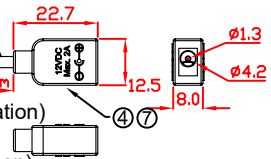

with power adapter
 (O/P:12VDC 2A)

L:
 CBL-D302MBSSWBPW-20m 20000mm±50mm

No	MATERIALS LIST:
1.	CABLE:UL2725 (28AWG*1PR+D+AM)x2C+28AWG*1PR+24AWG*1C+AM+B OD:5.6mm PVC JACKET COLOR:BLACK
2.	CONNECTOR:USB 3.0 A/M, 9P, BLUE INSULATOR SOLDER TYPE, NICKEL PLATED SHELL
3.	CONNECTOR:USB 3.0 MicroB/M, 10P, BLACK INSULATOR SOLDER TYPE, NICKEL PLATED SHELL
4.	PVC MOLDED HOUSING, BLACK COLOR
5.	SCREW:#4x33 M2
6.	SCREW:#4x34.5 M2
7.	DC JACK 1.3mm 30V 0.3V
8.	ABS HOUSING, BLACK COLOR

PIN OUT

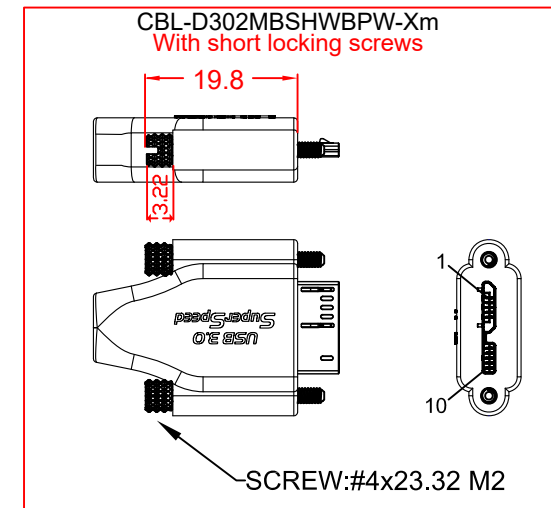
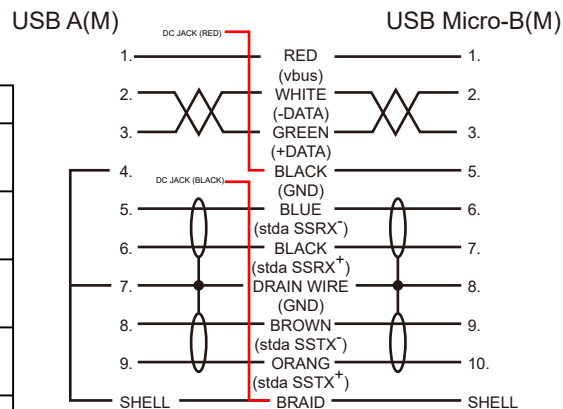

Jargy part no.	Client part no.	Approved	SCALE	UNIT
CBL-D302MBSSWBPW-20m				mm
Drawing Name		Drawn	Date	REV.
USB 3.0 A to MicroB Cable M/M				1.0

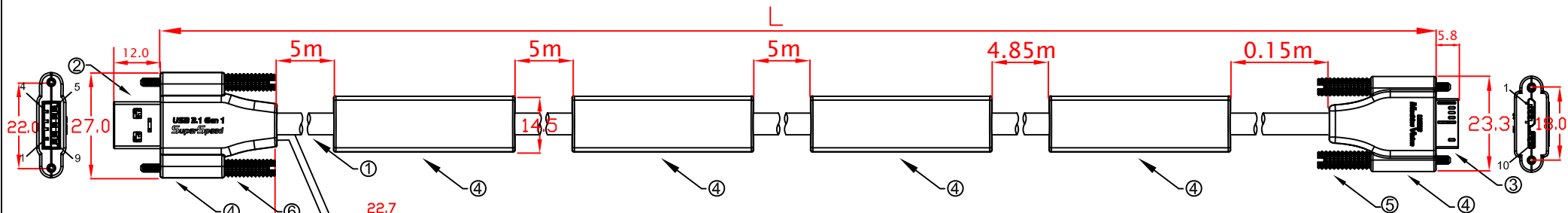
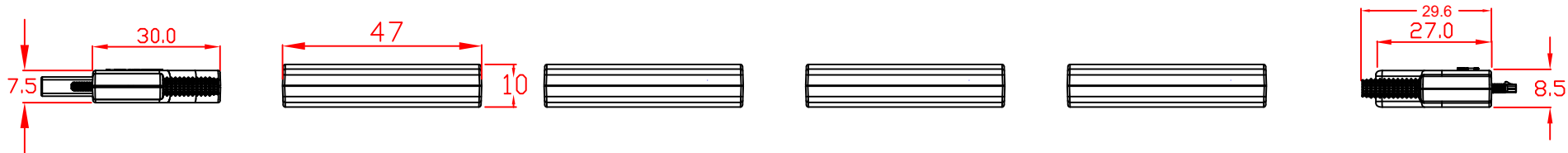

Operating Temperature: 0°C~70°C
 Operating Humidity: 20%~80% (no condensation)
 Storage Temperature: -25°C~85°C
 Storage Humidity: 20%~80% (no condensation)

L:

CBL-D302MBSSWPW-20m 20000mm±50mm

with power adapter
 (O/P:12VDC 2A)

PIN OUT

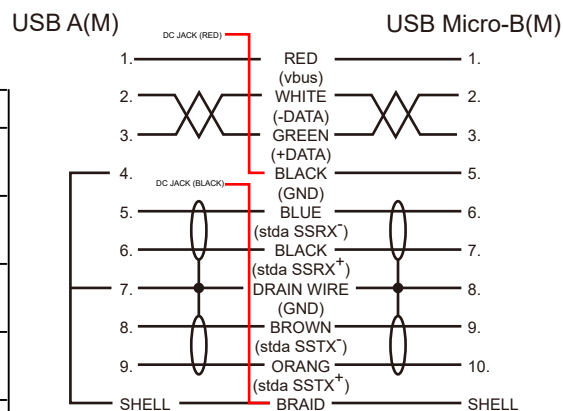

CBL-D302MBSHWBPW-Xm
 With short locking screws

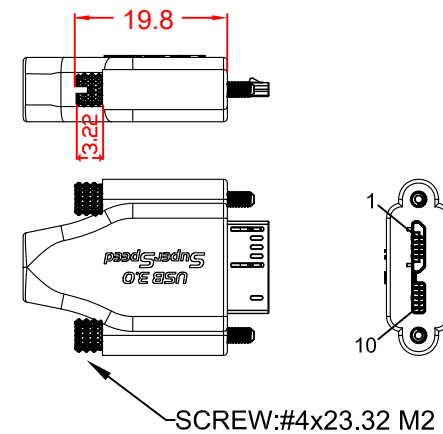

No	MATERIALS LIST:
1.	CABLE:UL2725 (28AWG*1PR+D+AM)x2C+28AWG*1PR+24AWG*1C+AM+B OD:5.6mm PVC JACKET COLOR:BLACK
2.	CONNECTOR:USB 3.0 A/M, 9P, BLUE INSULATOR SOLDER TYPE, NICKEL PLATED SHELL
3.	CONNECTOR:USB 3.1 TYPE-C, MALE, NICKEL PLATED SHELL
4.	ABS HOUSING, BLACK COLOR
5.	SCREW:#4x33 M2
6.	SCREW:#4x34.5 M2
7.	DC JACK 1.3mm 30V 0.3V
8.	PVC MOLDED HOUSING, BLACK COLOR

Jargy part no.	Client part no.	Approved	SCALE	UNIT
CBL-D302MBSSWPW-20m				mm
Drawing Name		Drawn	Date	REV.
USB 3.1 GEN 1 A to C M/M				1.0



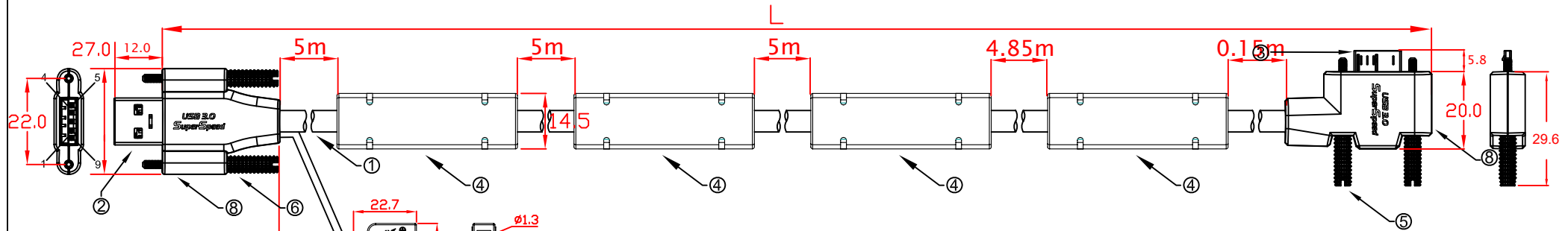
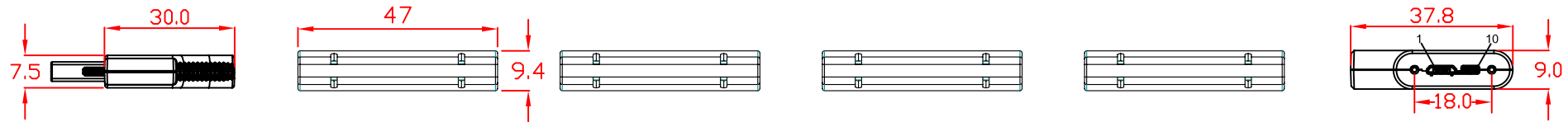

Operating Temperature: 0°C~70°C
 Operating Humidity: 20%~80% (no condensation)
 Storage Temperature: -25°C~85°C
 Storage Humidity: 20%~80% (no condensation)

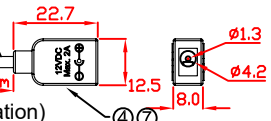

with power adapter
 (O/P:12VDC 2A)

L:
 CBL-D302MBSSWPW-20mLA 20000mm±50mm

No	MATERIALS LIST:
1.	CABLE:UL2725 (28AWG*1PR+D+AM)x2C+28AWG*1PR+24AWG*1C+AM+B OD:5.6mm PVC JACKET COLOR:BLACK
2.	CONNECTOR:USB 3.0 A/M, 9P, BLUE INSULATOR SOLDER TYPE, NICKEL PLATED SHELL
3.	CONNECTOR:USB 3.0 MicroB/M, 10P, BLACK INSULATOR SOLDER TYPE, NICKEL PLATED SHELL
4.	PVC MOLDED HOUSING, BLACK COLOR
5.	SCREW:#4x33 M2
6.	SCREW:#4x34.5 M2
7.	DC JACK 1.3mm 30V 0.3V
8.	ABS HOUSING, BLACK COLOR

PIN OUT

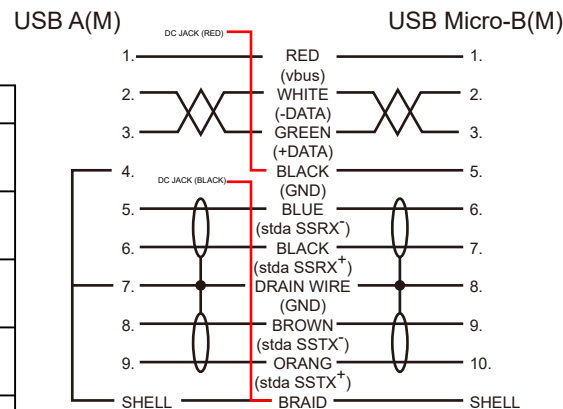

CBL-D302MBHWBPW-XmLA
 With short locking screws

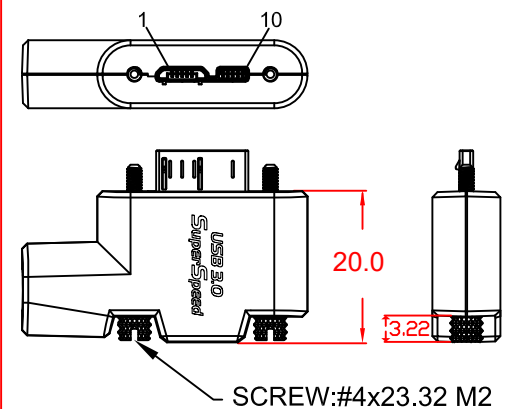

Jargy part no.	Client part no.	Approved	SCALE	UNIT
CBL-D302MBSSWPW-20mLA				mm
Drawing Name		Drawn	Date	REV.
USB 3.0 A to MicroB Cable M/M				1.0

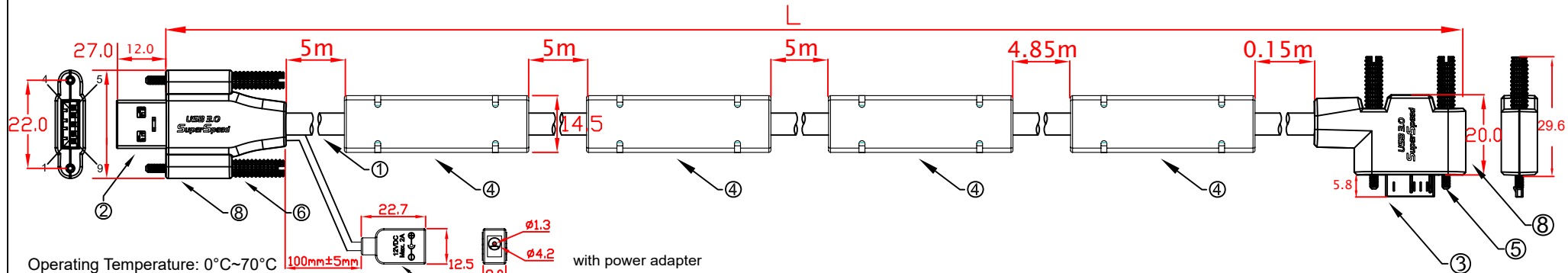
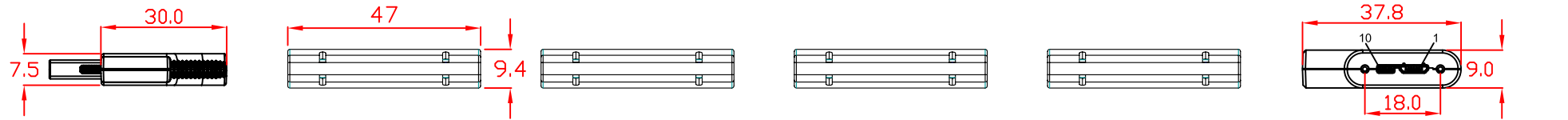

Operating Temperature: 0°C~70°C
 Operating Humidity: 20%~80% (no condensation)
 Storage Temperature: -25°C~85°C
 Storage Humidity: 20%~80% (no condensation)

with power adapter
 (O/P:12VDC 2A)

L:
 CBL-D302MBSSWBPW-20mRA 20000mm±50mm

No	MATERIALS LIST:
1.	CABLE:UL2725 (28AWG*1PR+D+AM)x2C+28AWG*1PR+24AWG*1C+AM+B OD:5.6mm PVC JACKET COLOR:BLACK
2.	CONNECTOR:USB 3.0 A/M, 9P, BLUE INSULATOR SOLDER TYPE, NICKEL PLATED SHELL
3.	CONNECTOR:USB 3.0 MicroB/M, 10P, BLACK INSULATOR SOLDER TYPE, NICKEL PLATED SHELL
4.	PVC MOLDED HOUSING, BLACK COLOR
5.	SCREW:#4x33 M2
6.	SCREW:#4x34.5 M2
7.	DC JACK 1.3mm 30V 0.3V
8.	ABS HOUSING, BLACK COLOR

PIN OUT

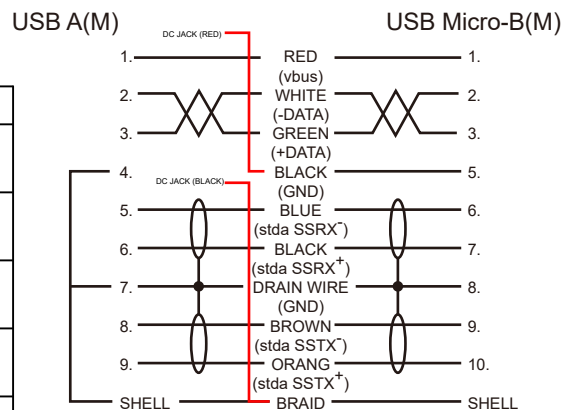

CBL-D302MBSHWBPW-XmRA
 With short locking screws

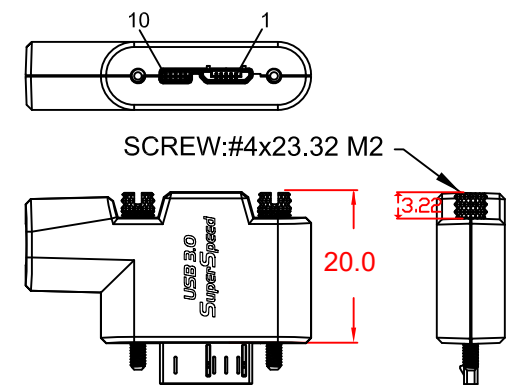

Jargy part no.	Client part no.	Approved	SCALE	UNIT
CBL-D302MBSSWBPW-20mRA				mm
Drawing Name		Drawn	Date	REV.
USB 3.0 A to MicroB Cable M/M				1.0

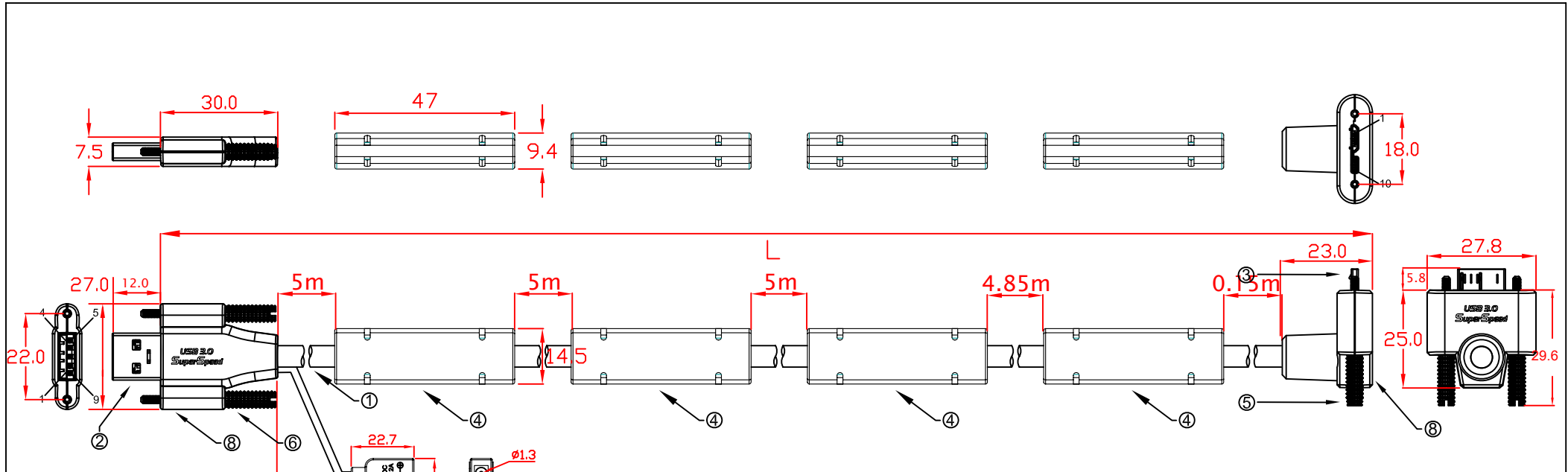

Operating Temperature: 0°C~70°C
 Operating Humidity: 20%~80% (no condensation)
 Storage Temperature: -25°C~85°C
 Storage Humidity: 20%~80% (no condensation)

L:
 CBL-D302MBSSWBPW-20mUA 20000mm±50mm

with power adapter
 (O/P:12VDC 2A)

PIN OUT

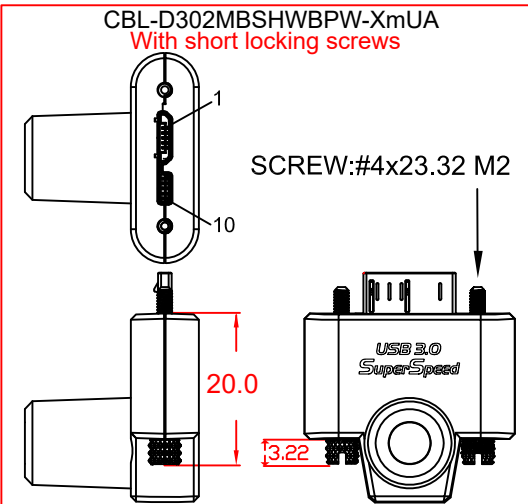
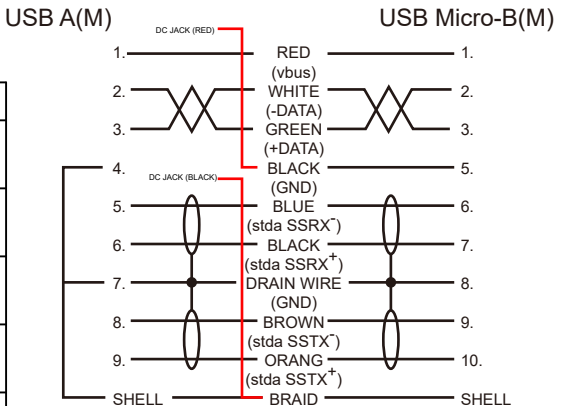

No	MATERIALS LIST:
1.	CABLE:UL2725 (28AWG*1PR+D+AM)x2C+28AWG*1PR+24AWG*1C+AM+B OD:5.6mm PVC JACKET COLOR:BLACK
2.	CONNECTOR:USB 3.0 A/M, 9P, BLUE INSULATOR SOLDER TYPE, NICKEL PLATED SHELL
3.	CONNECTOR:USB 3.0 MicroB/M, 10P, BLACK INSULATOR SOLDER TYPE, NICKEL PLATED SHELL
4.	PVC MOLDED HOUSING, BLACK COLOR
5.	SCREW:#4x33 M2
6.	SCREW:#4x34.5 M2
7.	DC JACK 1.3mm 30V 0.3V
8.	ABS HOUSING, BLACK COLOR

Jargy part no.	Client part no.	Approved	SCALE	UNIT
CBL-D302MBSSWBPW-20mUA				mm
Drawing Name		Drawn	Date	REV.
USB 3.0 A to MicroB Cable M/M				1.0

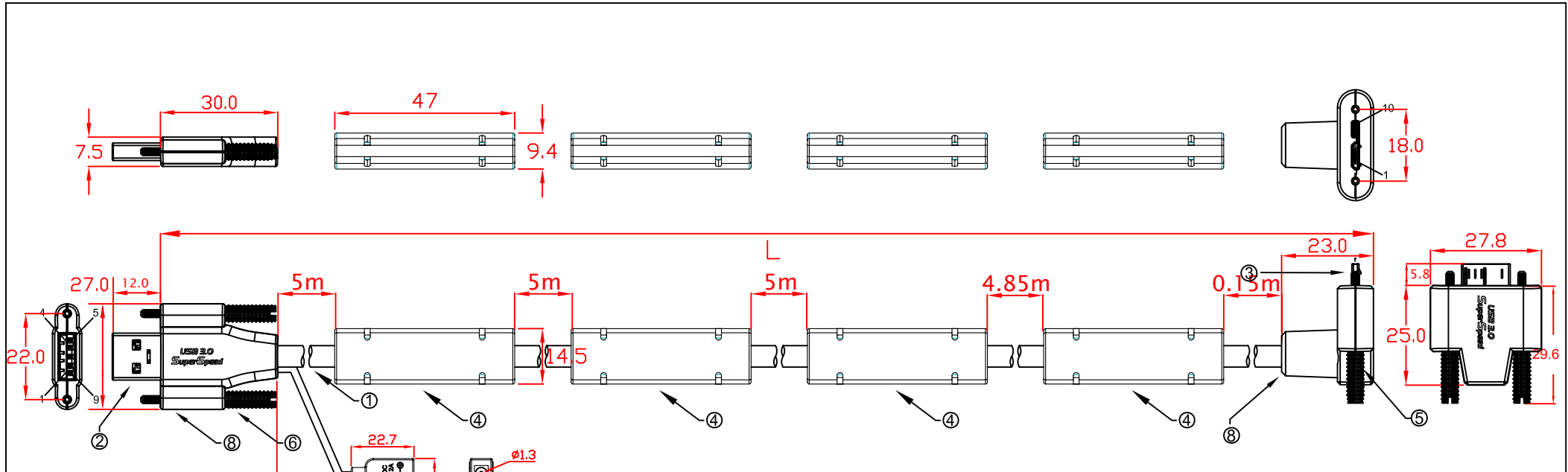

Operating Temperature: 0°C~70°C
 Operating Humidity: 20%~80% (no condensation)
 Storage Temperature: -25°C~85°C
 Storage Humidity: 20%~80% (no condensation)

L:
 CBL-D302MBSSWPW-20mDA 20000mm±50mm

with power adapter
 (O/P:12VDC 2A)

PIN OUT

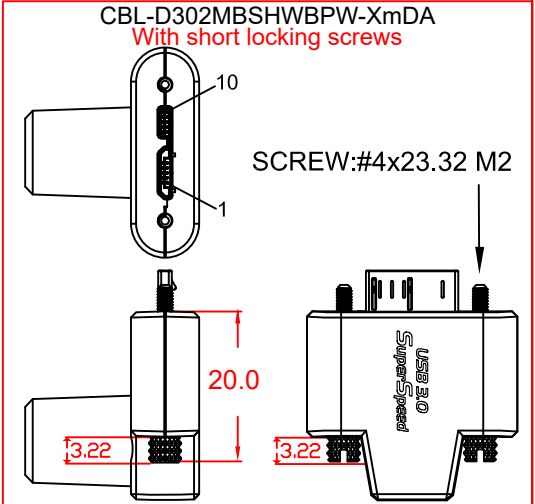
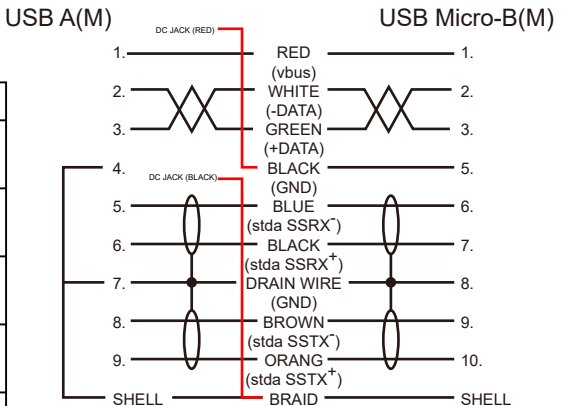

No	MATERIALS LIST:
1.	CABLE:UL2725 (28AWG*1PR+D+AM)x2C+28AWG*1PR+24AWG*1C+AM+B OD:5.6mm PVC JACKET COLOR:BLACK
2.	CONNECTOR:USB 3.0 A/M, 9P, BLUE INSULATOR SOLDER TYPE, NICKEL PLATED SHELL
3.	CONNECTOR:USB 3.0 MicroB/M, 10P, BLACK INSULATOR SOLDER TYPE, NICKEL PLATED SHELL
4.	PVC MOLDED HOUSING, BLACK COLOR
5.	SCREW:#4x33 M2
6.	SCREW:#4x34.5 M2
7.	DC JACK 1.3mm 30V 0.3V
8.	ABS HOUSING, BLACK COLOR

Jargy part no.	Client part no.	Approved	SCALE	UNIT
CBL-D302MBSSWPW-20mDA				mm
Drawing Name		Drawn	Date	REV.
USB 3.0 A to MicroB Cable M/M				1.0